

CAUTION: Adhesive bonds on contact. Please read entire instructions first.

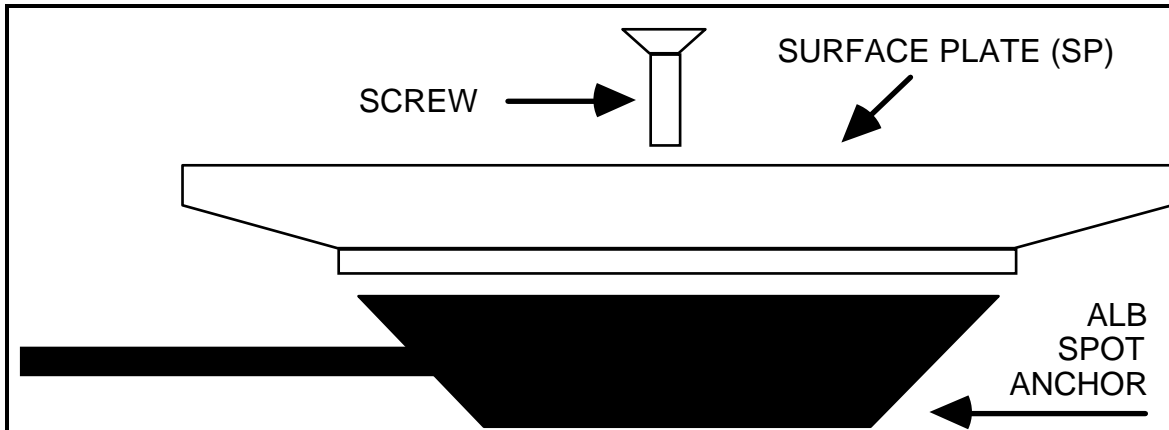

To assemble the ALBSP anchor:

First you must attach the Surface Plate (SP) to the Spot Anchor (ALB).

- Place the Spot Anchor label-down on a level surface. Apply a liberal bead of adhesive to the Spot Anchor spiraling out from the center. Proceed immediately.

Caution: Adhesive bonds instantly so it is essential to align the screw holes before the Surface Plate and the Spot Anchor make contact. Adhesive is moisture activated so it may be helpful to lightly blow on wet adhesive.

- With the screw in the Surface Plate, position the plate above the anchor as shown in the above diagram, holding the SP in one hand and a screwdriver in the other.
- Before allowing the plate to contact the anchor, use the screwdriver in the screw to locate the hole in the Spot Anchor with the tip of the screw. Once you begin threading the screw, the plate may contact the anchor. Tighten the screw firmly.
- Wipe away any excess adhesive with a tissue where it oozes around the edges.



To install the ALBSP Spot Anchor on your equipment:

- Select the best anchor location by positioning your equipment where it will be used. Consider the position of each piece of equipment to be secured, where all the anchors and cables will be located, and the direction of the anchor loops. Be certain the mounting surface is completely flat and has no curves.
- Anchors are best applied when the equipment surface is horizontal. Tip equipment if necessary. Clean gluing surface.

Note: If you are applying the anchor to a painted metal surface, a secure bond may be difficult. Remove the paint in advance by lightly sanding.

- Apply a liberal bead of adhesive to the Surface Plate spiraling out from the center. The adhesive is moisture activated so it may be helpful to lightly blow on the wet adhesive. Use enough adhesive so that when the plate is mounted, its mounting surface will become completely covered with adhesive.
- Press the Surface Plate against the equipment case without twisting and hold it in place firmly for at least 30 seconds. It is normal for some adhesive to ooze out the sides. Wipe away any excess adhesive with a tissue.
- Allow several hours to set. Maximum bond is achieved after 24 hours. Once set, the plate cannot be moved or adjusted.

CAUTION: Avoid getting adhesive on skin, in eyes or on clothes. Keep out of the reach of children. Use with care.

Thank you for choosing SecurTech